

Description

Posifa designed the PMF4000 series of Mass Air Flow Sensors from the ground up, incorporating the latest MEMS and microelectronics innovations. The sensor die uses a pair of thermopiles to detect changes in temperature gradient caused by mass flow, delivering excellent signal-to-noise, and unsurpassed repeatability. The “solid state” thermal isolation on the sensor die eliminates the need for surface cavity or fragile membranes used in competing solutions, making the sensor resistant to clogging and pressure shock. The sensor’s internal signal conditioning circuitry leverages an off-the-shelf microcontroller, providing proven reliability and low cost.

The PMF4000 series of Mass Air Flow Sensors covers the ranges from 12 SLM to 300 SLM. The sensors are temperature compensated over the temperature range of 0 to 50 °C (32 to 122 °F). The linearized analog output (1 to 5 V) provides maximum flexibility and ease-of-use.

Applications

- Oxygen concentrators
- Oxygen conservers
- Respirators and ventilators
- Nebulizers
- Continuous positive airway pressure (CPAP) equipment
- Anesthesia delivery
- Leak detection
- Spectroscopy
- Mass flow controllers
- Telecommunication systems
- Environmental climate controls
- Fuel cell controls



Features

- Unsurpassed performance in a robust and cost effective package
- High accuracy (2% F.S. typ.*)
- Linear output and temperature compensation
- Long-term stability with minimal null drift
- “Solid state” sensing core (no surface cavity or fragile membrane), resistant to clogging and pressure shock
- Analog output (1 to 5 V)**
- Fast response time (1 ms typ.)
- Custom ranges between 10 SLM and 300 SLM

* 2% F.S. max option is available

**Custom output between 0 to 3V options are also available (e.g. 0.3 to 2 V output)

Maximum Ratings

- Operating Temperature: -25 °C to 85 °C
- Storage Temperature: -40 °C to 90 °C
- Humidity: 0 to 100% RH *
- Shock 100 g peak (5 drops, 3 axis)
- Common Mode Pressure: 25 psi

* Sensor is resistant to water condensation

ELECTRICAL CHARACTERISTICS						
Test Conditions: Vin=10±0.01VDC, Ta=25°C. Relative Humidity: 40%<RH<60%						
Maximum Operating Temperature Range -25°C to +85°C						
	Flow Range ¹					
PMF4003V	0 .. 12		SLM ²			
PMF4004V	0 .. 20		SLM			
PMF4005V	0 .. 35		SLM			
PMF4100V	0 .. 50		SLM			
PMF4101V	0 .. 100		SLM			
PMF4102V	0 .. 150		SLM			
PMF4103V	0 .. 200		SLM			
PMF4104V	0 .. 300		SLM			
SPECIFICATIONS	MIN	TYP	MAX	UNIT	CONDITIONS	
Analog Voltage Output ³	1		5	VDC		
Null Voltage	.95	1	1.05	VDC		
Null Drift		0.2		% F.S.	Per year	
Repeatability		0.1		% F.S.		
Load		100		KΩ		
Accuracy (Full Scale) ⁴		2	3	% F.S.	0°C to +50°C	
Response Time		1	3	mSec		
Supply Voltage ⁵	8	10	14	VDC		
Supply Current	22		23	mA		
Wetted Materials	Silicon carbide, Epoxy, PPS, FR4, Silicone as static seal					

1. Custom ranges available between 10 and 300 SLM

2. SLM: standard liter per minute. Standard conditions: 0 °C and 1 atmosphere

3. Custom output between 0 to 3 V options are available, e.g. 0.3 to 2 V output

4. Includes temperature drift and linearity error; 2% F.S. max option available.

5. 5 V supply voltage option is available

Linear Output

Flow Rate = $[(V_{out} - 1 V) / 4 V] \times \text{Full Scale Flow Rate}$

For example, PMF4103V has a Full Scale Flow Rate of 200 SLM. When the Output Voltage reads 2.5V, the Flow Rate will be: $[(2.5V-1V)/4V \times 200 \text{ SLM}] = 75 \text{ SLM}$

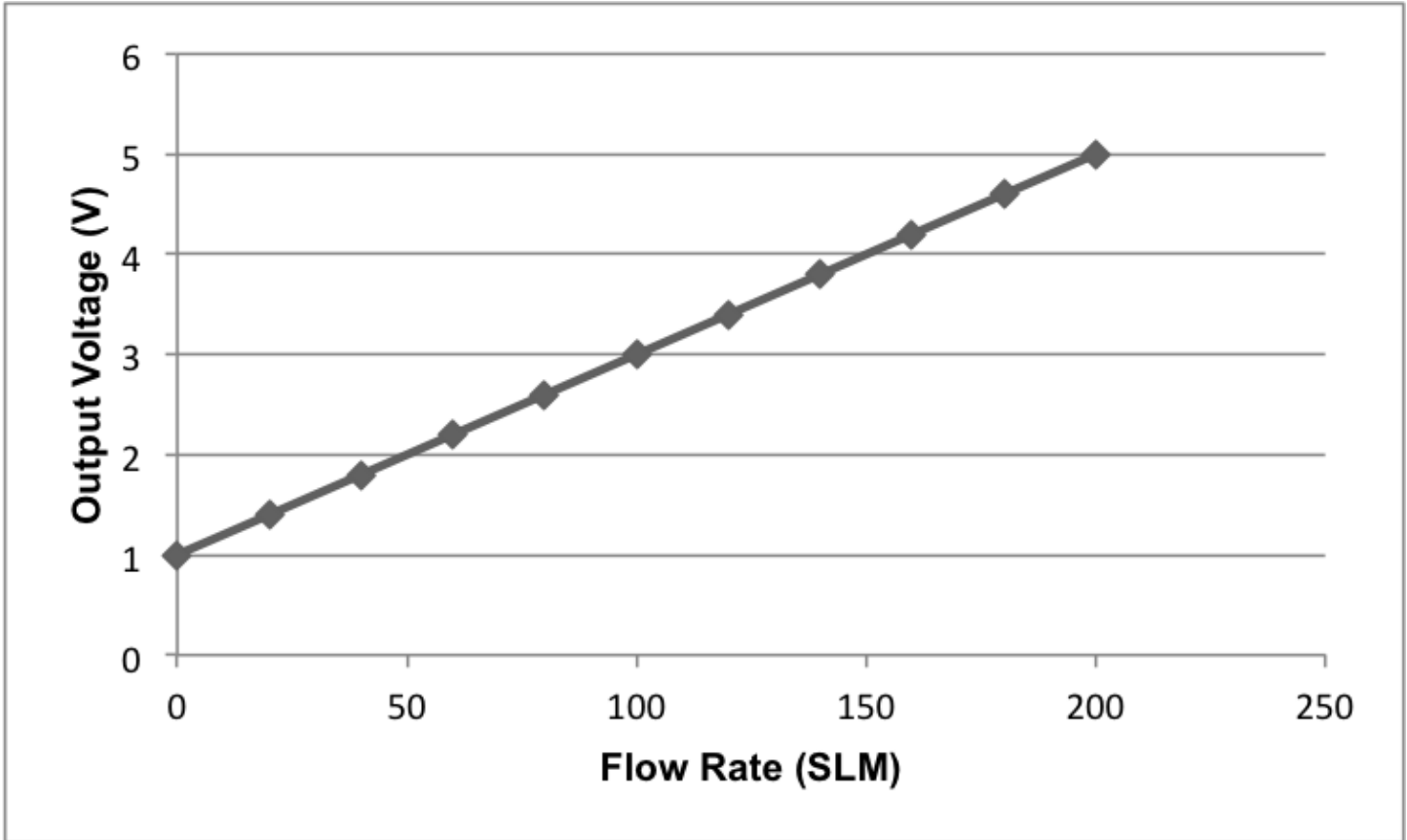

Package Dimensions

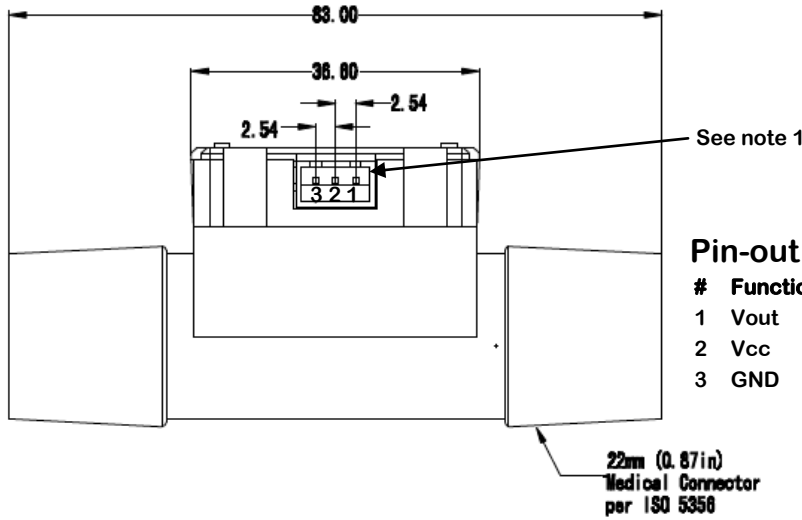

Mating Connector

Pin-out

#	Function	Wire Color
1	Vout	Yellow
2	Vcc	Red
3	GND	Grey

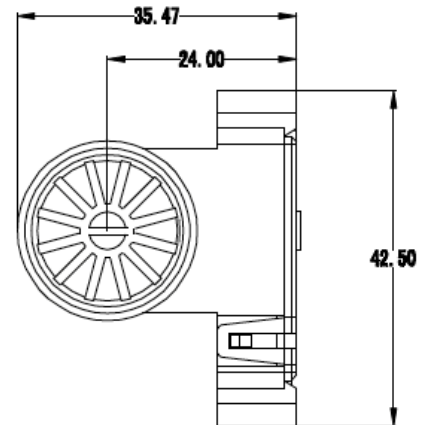
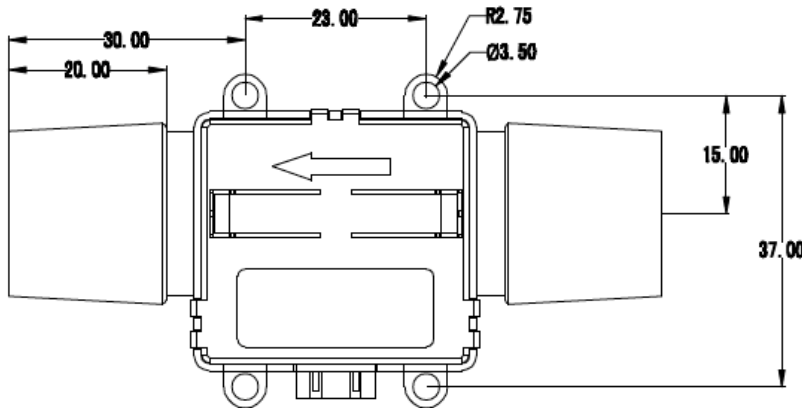

Note 1: Mating connector with 12 inch pigtail provided.

Ordering Information

Part Number	Specifications
PMF4003V	1 to 5 V, linear; 0 to 12 SLM
PMF4004V	1 to 5 V, linear; 0 to 20 SLM
PMF4005V	1 to 5 V, linear; 0 to 35 SLM
PMF4100V	1 to 5 V, linear; 0 to 50 SLM
PMF4101V	1 to 5 V, linear; 0 to 100 SLM
PMF4102V	1 to 5 V, linear; 0 to 150 SLM
PMF4103V	1 to 5 V, linear; 0 to 200 SLM
PMF4104V	1 to 5 V, linear; 0 to 300 SLM